

Hong Kong Physics Olympiad 2023

2023 年香港物理奧林匹克競賽

Organisers 合辦機構

Education Bureau

教育局

The Hong Kong Academy for Gifted Education

香港資優教育學苑

The Hong Kong University of Science and Technology

香港科技大學

Advisory Organisations 顧問機構

The Physical Society of Hong Kong

香港物理學會

Hong Kong Physics Olympiad Committee

香港物理奧林匹克委員會

14 May, 2023

2023 年 5 月 14 日

Rules and Regulations 競賽規則

1. All questions are in bilingual versions. You can answer in either Chinese or English, but only ONE language should be used throughout the whole paper.
所有題目均為中英對照。你可選擇以中文或英文作答，惟全卷必須以單一語言作答。
2. The multiple-choice answer sheet will be collected 1.5 hours after the start of the contest. You can start answering the open-ended questions any time after you have completed the multiple-choice questions without waiting for announcements.
選擇題的答題紙將於比賽後一小時三十分收回。若你在這之前已完成了選擇題，你亦可開始作答開放式題目，而無須等候任何宣佈。
3. On the cover of the answer book and the multiple-choice answer sheet, please write your 8-digit Contestant Number, English Name, and Seat Number.
在答題簿封面及選擇題答題紙上，請填上你的 8 位數字參賽者號碼、英文姓名、及座位號碼。
4. After you have made the choice in answering a multiple choice question, fill the corresponding circle on the multiple-choice answer sheet **fully** using a HB pencil.
選定選擇題的答案後，請將選擇題答題紙上相應的圓圈用 HB 鉛筆**完全塗黑**。
5. The open-ended problems are quite long. Please read the whole problem first before attempting to solve them. If there are parts that you cannot solve, you are allowed to treat the answer as a known answer to solve the other parts.
開放式問答题較長，請將整題閱讀完後再著手解題。若某些部分不會做，也可把它們的答案當作已知來做其他部分。
6. All numerical answers must be in (at least) 3 significant digits.
所有的數值答案必須保留至少 3 個有效數字。

The following symbols and constants are used throughout the examination paper unless otherwise specified:

除非特別注明，否則本卷將使用下列符號和常數：

Gravitational acceleration on Earth surface 地球表面重力加速度	g	9.80 m s^{-2}
Gravitational constant 重力常數	G	$6.67 \times 10^{-11} \text{ m}^3\text{kg}^{-1}\text{s}^{-2}$

There is no friction in the problems unless otherwise specified.
問題中若無特別說明，則不存在摩擦。

Multiple Choice Questions (2 Marks Each) 選擇題(每題 2 分)

The following information is used for questions 1 and 2.

以下資料用於問題 1 和 2。

Three blocks of identical mass are placed on a frictionless table as shown. The center block is at rest, whereas the other two blocks are moving directly towards it at identical speeds v . The center block is initially closer to the left block than the right one. All motion takes place along a single horizontal line.

如圖所示，將三個質量相同的物體放在無摩擦的桌子上。中間物體處於靜止狀態，而其他兩個物體正以相同的速度 v 直接朝它移動。中間物體最初更靠近左側物體。所有運動都沿著同一條水平線發生。



1. Suppose that all collisions are instantaneous and **completely elastic**. After a long time, which of the following is true?

1. 假設所有碰撞都是瞬時的並且是**完全彈性**的。過了很長時間，以下哪項是正確的？

- A. The center block is moving to the left. 中心物體向左移動。
- B. The center block is moving to the right. 中心物體向右移動。
- C. The center block is at rest somewhere to the left of its initial position. 中心物體在其初始位置左側的某處靜止。
- D. The center block is at rest at its initial position. 中心物體在其初始位置處於靜止狀態。
- E. The center block is at rest somewhere to the right of its initial position. 中心物體在其初始位置右側的某處靜止。

2. Suppose, instead, that all collisions are instantaneous and **perfectly inelastic**. After a long time, which of the following is true?

2. 相反，假設所有碰撞都是瞬時且**完全不彈性**的。過了很長時間，以下哪項是正確的？

- A. The center block is moving to the left. 中心物體向左移動。
- B. The center block is moving to the right. 中心物體向右移動。
- C. The center block is at rest somewhere to the left of its initial position. 中心物體在其初始位置左側的某處靜止。
- D. The center block is at rest at its initial position. 中心物體在其初始位置處於靜止狀態。
- E. The center block is at rest somewhere to the right of its initial position. 中心物體在其初始位置右側的某處靜止。

3. An object is thrown with a fixed initial speed v_0 at angles α relative to the horizon. At some height h above the launch point the speed v of the object is measured as a function of the initial angle α . Which of the following best describes the dependence of v on α ? (Assume that there is no air resistance.)

3. 一個物體以固定的初始速率 v_0 以相對於地平線的角度 α 被拋出。在距離發射點高度 h 處，測量物體的速率 v 作為初始角 α 的函數。以下哪個最能描述 v 與 α 的關係？（假設沒有空氣阻力。）

- A. v will increase monotonically with α . v 會隨著 α 單調增加。
- B. v will increase to some critical value v_{max} and then decrease. v 會增加到某個臨界值 v_{max} ，然後減少。
- C. v will remain constant, independent of α . v 將保持不變，與 α 無關。
- D. v will decrease to some critical value v_{min} and then increase. v 將減少到某個臨界值 v_{min} ，然後增加。
- E. None of the above. 以上都不是。

4. In a lightweight seesaw, Albert (mass 70 kg), Isaac (mass 80 kg), and Marie (mass 60 kg) are seated in order with equal spacing of 2 m between them. Isaac is positioned between Albert and Marie in a way that balances the seesaw. Neglecting the mass of the seesaw, determine which person exerts the greatest magnitude of torque (relative to the center of the seesaw) on the seesaw.

4. 在一個輕型蹺蹺板上，Albert（質量 70 kg）、Isaac（質量 80 kg）和 Marie（質量 60 kg）按順序坐下，他們之間間距為 2 m。Isaac 位於 Albert 和 Marie 之間，並且維持蹺蹺板的平衡。忽略蹺蹺板的質量，請問哪個人在蹺蹺板上施加了最大的力矩（相對於蹺蹺板的中心）。

- A. Albert
- B. Isaac
- C. Marie
- D. They all exert the same torque. 它們都施加相同的力矩。
- E. There is not enough information to answer the question. 沒有足夠的信息來回答問題。

5. A mass is suspended from the ceiling of a box by an ideal spring. The mass is given an initial velocity and oscillates vertically while the box is held fixed. When the mass reaches the lowest point of its motion, the box is released and fall. To an observer inside the box, which of the following quantities does not change when the box is released? Ignore air resistance.

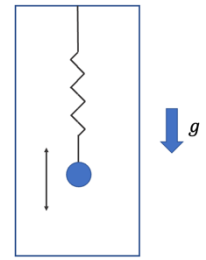

5. 一個物塊通過一個理想彈簧懸掛在盒子的天花板上。質量被賦予初始速度並於盒子固定靜止時垂直振盪。當物塊到達其運動的最低點時，盒子被釋放並下落。對於盒子內的觀察者，當盒子被釋放時，下列哪個量不會改變？可忽略空氣阻力。

- A. The amplitude of the oscillation 振盪幅度
- B. The period of the oscillation 振盪週期
- C. The maximum speed reached by the mass 物塊的最大速度
- D. The height at which the mass reaches its maximum speed 物塊達到最大速率時的高度
- E. The maximum height reached by the mass 物塊達到的最大高度

6. Two objects A and B are launched at the same time and place from ground on the Moon (no air). Object A is launched with speed 10 m/s at an angle of θ above horizon. Object B is launched with speed 10 m/s at an angle of $\theta + 60^\circ$ measured in the same way. What is the distance between A and B after two seconds. It is given that at this moment neither A nor B has hit the ground yet.

6. 兩物體 A 和 B 同時同地從月球表面（沒有空氣）發射。物體 A 以 10 m/s 的速率從地平線向上以角度 θ 發射。物體 B 以 10 m/s 的速率從同一方向地平線向上以角度 $\theta + 60^\circ$ 發射。兩秒後 A 和 B 之間的距離是多少？假設此時 A 和 B 都還沒有落地。

- A. 5 m
- B. 10 m
- C. $10\sqrt{2}\text{ m}$
- D. $10\sqrt{3}\text{ m}$
- E. 20 m

7. All numbers in this question are in units of m/s and \hat{i} and \hat{j} are two perpendicular unit vectors.

An object consisting of two parts of unknown masses separated by a massless compressed spring moves with constant initial velocity \hat{i} . At a certain moment the spring is released to push the two parts apart. Ignoring friction and gravity, which of the following velocities is/are possible at a certain time after the spring is released?

7. 本題中所有數字的單位都是 m/s ， \hat{i} 和 \hat{j} 是兩個垂直的單位向量。

一個物體由兩未知質量的部分組成，被無質量壓縮彈簧分開，並以恆定的初始速度 \hat{i} 運動。彈簧在某個時刻伸展並將兩個部分推開。如忽略摩擦力和重力，以下哪組彈簧伸展後某刻兩部分的速度是可能的？

- I. $\vec{v}_A = \hat{i} - \hat{j}, \vec{v}_B = -\hat{i} + \hat{j}$
- II. $\vec{v}_A = \hat{i} + \hat{j}, \vec{v}_B = \hat{i} - \hat{j}$
- III. $\vec{v}_A = \hat{j}, \vec{v}_B = \hat{i} + \hat{j}$
- IV. $\vec{v}_A = \hat{i} + \hat{j}, \vec{v}_B = \hat{i} - 2\hat{j}$

- A. I only
- B. II only
- C. None
- D. II and III only
- E. II and IV only

8. All numbers in this question are in units of m/s .

A projectile loaded with explosive is launched from ground at the origin and hit the ground again at a displacement $D\hat{i}$, where $D > 0$ and \hat{i} is in a horizontal direction. It is then launched again for a second time in exactly the same way but this time the explosive explodes when it has velocity $3\hat{i} - 2\hat{j}$, where \hat{j} is in the vertically upward direction. Due to the explosion it splits into two parts A and B . Denote the velocities of A and B just after the explosion by \vec{v}_A and \vec{v}_B , respectively. Assume that each part stops immediately after hitting the ground. Denote the final position of the center of mass after both parts hit the ground by $D_{CM}\hat{i}$. In which of the following case(s) will D_{CM} be greater than D ?

8. 本題所有數字的單位都是 m/s 。

一裝有炸藥的物體從地面於原點發射，並於位移為 $D\hat{i}$ 處再次撞擊地面，其中 $D > 0$ 且 \hat{i} 為水平方向。後該物體以完全相同的方式再次被發射，但這次炸藥在物體速度為 $3\hat{i} - 2\hat{j}$ 時爆炸，其中 \hat{j} 為垂直向上方向。爆炸後物體分裂成 A 和 B 兩部分。分別以 \vec{v}_A 和 \vec{v}_B 表示爆炸剛過後 A 和 B 的速度。假設每個部分在觸地後立即停止。以 $D_{CM}\hat{i}$ 表示兩個部分都觸地後質心的最終位置。在以下哪種情況下 D_{CM} 會大於 D ？

- I. $\vec{v}_A = \hat{i} - 2\hat{j}, \vec{v}_B = 4\hat{i} - 2\hat{j}$
- II. $\vec{v}_A = -\hat{i} - 6\hat{j}, \vec{v}_B = 5\hat{i}$
- III. $\vec{v}_A = -3\hat{j}, \vec{v}_B = \frac{9}{2}\hat{i} - \frac{3}{2}\hat{j}$

- A. I only
- B. II only
- C. III only
- D. None
- E. II and III only

9. A 1.00-kg mass is attached to a horizontal spring with a spring constant of 10 N/m to move on a rough horizontal surface. Let the line of motion be the x -axis and the mass is at the origin when the spring is unstretched. The coefficient of static friction and kinetic friction are 0.40 and 0.30, respectively. The mass is initially at the origin, and is given an initial speed of 1.00 m/s in the positive x direction. What is the position at which the mass will come to a complete stop?

9. 一個 1.00 千克的物體連接到彈力係數為 10 N/m 的水平彈簧上，並在粗糙的水平表面上移動。設物體沿 x 軸運動，並在彈簧未伸展時位於原點。已知靜摩擦係數和動摩擦係數分別為 0.40 和 0.30。物體最初於原點以初始速度 1.00 m/s 向正 x 方向運動。問物體最終將完全停止於什麼位置？

- A. 0.138 m B. 0.255 m C. 0.383 m D. 0.457 m E. -0.726 m

10. Following question 9, what is the answer if the initial velocity is increased to 2.00 m/s in the positive x direction?

10. 續題 9，假設物體向正 x 方向的初始速度增加到 2.00 m/s，則答案該為什麼？

- A. 0.185 m B. 0.403 m C. -0.991 m D. -0.185 m E. -0.255 m

11. Two identical triangles with mass m are placed on a frictional horizontal surface. A sphere with mass M is held by the triangles without falling, as shown in the diagram below. Consider that the surface between the sphere and triangles is frictionless, find the minimum value of the coefficient of static friction between the triangle and the surface such that the triangles will not slide away.

11. 兩個相同的質量為 m 的三角形放在有摩擦力的水平面上。如下圖所示，質量為 M 的球體被三角形固定而不會掉落。考慮球體與三角形之間的表面是無摩擦力的，求三角形與表面之間的靜摩擦係數的最小值使得三角形不會滑落。

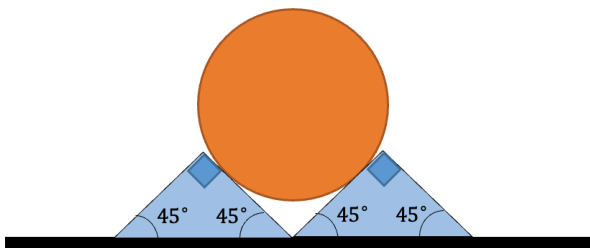

- A. $\frac{m}{M}$ B. $\frac{2M}{m}$ C. $\frac{1}{2}$ D. $\frac{M}{m+M}$ E. $\frac{M}{2m+M}$

Q12 and Q13 concern the same situation below.

A mass m is hanging on a massless ring which slides through a straight cable that makes a 30° angle with the horizontal as shown in the figure. There may be friction between the ring and the cable. The mass accelerates along a straight line parallel to the cable above.

Q12 和 Q13 涉及以下相同情況。

質量 m 掛在一個無質量環上，該環通過一條與水平面成 30° 角的直纜索滑動，如圖所示。環和纜索之間可能存在摩擦力。質量沿著平行於上方纜索的直線加速。

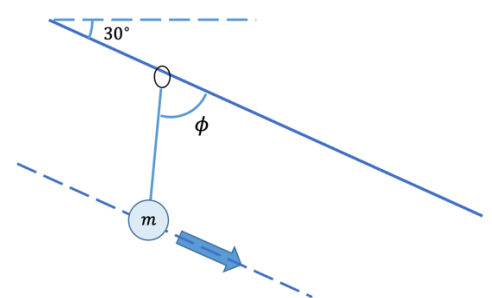

12. If the angle, ϕ , between the cable and the string hanging the mass is 90° , what is the magnitude of the friction between the ring and the cable?

12. 如果纜索和懸掛質量的繩子之間的角度 ϕ 是 90° ，那麼環和纜索之間的摩擦力大小是多少？

- A. 0 B. mg C. $\frac{mg}{2}$ D. $\frac{mg}{5}$ E. $2mg$

13. If the mass is accelerating down along the dotted line, what is the minimum value of ϕ ?

13. 如果質量沿著虛線加速下降，則 ϕ 的最小值是多少？

- A. 30° B. 45° C. 60° D. 90° E. 120°

14. Consider a mass m which is hanging vertically by a spring with spring constant k under constant gravity. The spring-mass system undergoes a simple harmonic oscillation with amplitude A . The largest magnitude of net force that acts on the mass during the oscillation is

14. 考慮一個質量 m 在恆定重力下由彈簧常數 k 的彈簧垂直懸掛。這彈簧—質量系統經歷振幅為 A 的簡諧振動。振盪期間作用在質量上的最大淨力為

- A. $kA - mg$ B. kA C. mg D. $m\omega^2 A$ E. $m\omega^2 A + mg$

15. A constant force $F = 800 \text{ N}$ applied horizontally to a block with mass $m = 100.0 \text{ kg}$ pushes the block up a surface that is inclined by $\theta = 15^\circ$ (see figure). The coefficient of kinetic friction between the block and the surface is μ_k . Under the application of the force, the velocity of the block increases from its initial value $v_1 = 1.50 \text{ m/s}$ to a final value $v_2 = 3.50 \text{ m/s}$ over a distance of $d = 2.20 \text{ m}$ along the surface. What is the work done by friction?

一道恆定的力 $F = 800 \text{ N}$ 水平地施加在質量為 $m = 100.0 \text{ kg}$ 的方塊上，將方塊沿着一斜面向上推，該斜面與水平傾斜 $\theta = 15^\circ$ (見圖)。方塊與斜面之間的動摩擦係數為 μ_k 。在該力的作用下，方塊的速度從其初始值 $v_1 = 1.50 \text{ m/s}$ 增加到最終值 $v_2 = 3.50 \text{ m/s}$ ，並沿斜面移動了 $d = 2.20 \text{ m}$ 。摩擦力所作的功是多少？

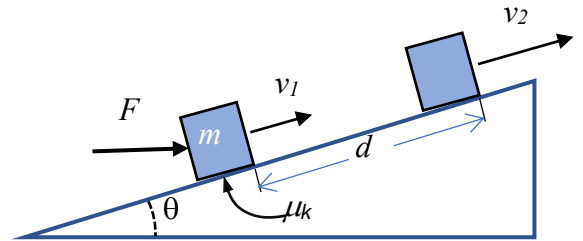

- A. -642 J B. 286 J C. -945 J D. -702 J E. 481 J

16. A cubic wooden block of width 20 cm is floating on a tank of water. When we push the block from the top side and displace it by a little, the block undergoes an up and down motion. Assume that the up and down motion of the block can be modelled as simple harmonic motion. What is the period of the simple harmonic motion of the block? The density of wood is 600 kg/m^3 . The density of water is 1000 kg/m^3 .

16. 一個邊長為 20 cm 的木質立方體浮在一個水槽上。當我們從頂部推動木塊並使其稍微移動時，木塊會上下運動。假設木塊的上下運動可以被建模為簡諧振動，該木塊的諧振運動週期是多少？木材密度為 600 kg/m^3 ，水的密度為 1000 kg/m^3 。

- A. 0.11 s B. 1.10 s C. 0.08 s D. 0.70 s E. 0.17 s

17. A rectangular block with dimensions $1.5 \text{ m} \times 1 \text{ m} \times 1 \text{ m}$ is placed on a slope that makes an angle of 30° with the horizontal. The square side of the rectangular block is initially put on the slope. The coefficient of static friction between the block and the slope is 0.5. Will the block slide down the slope, topple over, or neither?

17. 一個尺寸為 $1.5 \text{ m} \times 1 \text{ m} \times 1 \text{ m}$ 的長方體方塊被放在一個與水平面成 30° 角的斜面上。長方體的正方形面最初放在斜面上。方塊和斜面之間的靜摩擦係數為 0.5。該方塊會往下滑動、傾倒或是兩者都不會發生？

- A. The block will slide down the slope, but will not topple over. 方塊會往下滑動，但不會傾倒。
 B. The block will topple over, but will not slide down the slope. 方塊會傾倒，但不會往下滑動。
 C. The block will both slide down the slope and topple over. 方塊既會往下滑動也會傾倒。
 D. The block will neither slide down the slope nor topple over. 方塊既不會往下滑動也不會傾倒。
 E. Not enough information to decide. 資訊不足，無法確定。

18. A block of mass m is being pulled along an inclined surface at a constant velocity using two massless pulleys as shown in the diagram. The coefficient of kinetic friction between the block and the surface is 0.3. What is the magnitude of the pulling force F required to maintain the constant velocity? Assume the strings are massless and inextensible, and the mass of the block is 0.3 kg. The angle of inclination is $\theta = 30^\circ$.

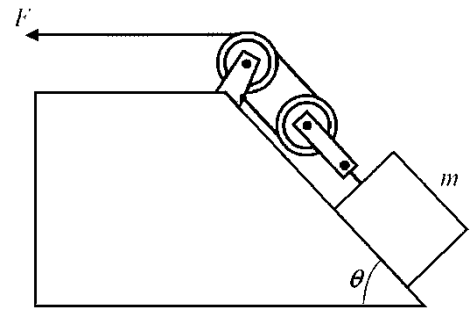

18. 如圖所示，一個質量為 m 的物體，被兩個無質量滑輪沿著斜面以恆定速度拉動。物體和斜面之間的動摩擦係數為 0.3。問維持恆定速度所需的拉力 F 的大小是多少？假設繩子是無質量和不可伸長，物體的質量為 0.3 kg。傾斜角度為 $\theta = 30^\circ$ 。

- A. 0.71 N B. 0.74 N C. 2.23 N D. 0.35 N E. 1.12 N

19. A man standing on a movable cart throws a ball towards a fixed wall outside the cart. The ball has an initial velocity of 15 m/s and bounces back from the wall, which the man then catches. The ball has a mass of 2 kg, the cart (with the man) has a mass of 80 kg and is initially at rest before the ball is thrown. Find the final speed of the cart. We assume the collision between the ball and the wall is elastic and the mass of the wall is much larger than that of the ball.

19. 一個站在可移動手推車上的人向著車外的一堵固定牆扔了一個球。球的初速度為 15 m/s，並且從牆上反彈，然後被接住。球的質量為 2 kg，手推車（和人）的質量為 80 kg，且在球被扔出去之前為靜止。求手推車的最終速度。假設球和牆壁之間的碰撞是彈性碰撞，並且牆壁的質量比球的質量大得多。

- A. 0.366 m/s B. 0.750 m/s C. 0 m/s D. 0.732 m/s E. 0.375 m/s

20. The rotor of a centrifuge rotates at 12,000 rpm (revolutions per minute). A particle at the top of a test tube (mounted on the centrifuge) is 5.00 cm from the rotation axis. Calculate the effective gravity of the particle feels. Assume the effect of the original gravity is negligible in this case.

20. 離心機轉速為 12,000 轉每分鐘。一顆位於測試管頂部，距離轉軸 5.00 cm 的微粒，所感受到的有效重力為多少？假設原重力的影響在此情況下可以忽略。

- A. 62.8 m/s² B. 10.0 m/s² C. 2000. m/s²
D. 79.0 × 10³ m/s² E. None of the above

Open Problems (15 Points Each) 開放題(每題 15 分)

1. [15 points] A small block X with mass m initially at height h starts to slide down a ramp from rest. It collides with a stationary small block Y on a horizontal surface, which has a mass of km for some number $k > 0$, as shown in the figure. Assume all collisions are perfectly elastic and friction can be neglected in this problem.

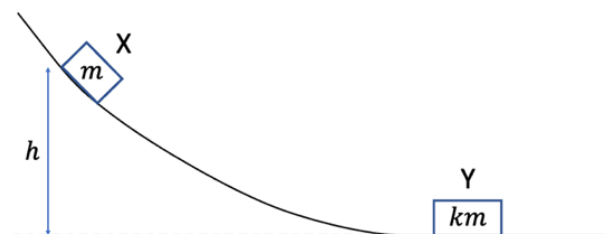

1. [15 分] 一個初始高度為 h 、質量為 m 的小塊 X 從靜止狀態開始滑下斜坡。它與水平表面上靜止的小塊 Y 相撞，該小塊 Y 的質量為 km ， $k > 0$ 為某一數值，如圖所示。假設所有碰撞都是完全彈性的，並且在此問題中可以忽略摩擦。

(a) [3] What is the velocity of X right before the collision with block Y?

(a) [3] X 在與 Y 碰撞之前的速度是多少？

(b) [3] What are the velocities of blocks X and Y after the first collision?

(b) [3] 第一次碰撞後小塊 X 和 Y 的速度是多少？

(c) [3] If two blocks can only collide exactly once, what condition must be satisfied for the value of k ?

(c) [3] 如果兩個小塊只能碰撞一次，那麼 k 的值必須滿足什麼條件？

(d) [3] Suppose the value of k does not satisfy the condition you found in part (c) and two blocks encounter the second collision. What are the velocities of blocks X and Y after the second collision?

(d) [3] 假設 k 的值不滿足你在 (c) 部分中找到的條件並且兩個小塊發生第二次碰撞。第二次碰撞後小塊 X 和 Y 的速度是多少？

(e) [3] If two blocks can only collide exactly twice, what condition must be satisfied for the value of k ?

(e) [3] 如果兩個小塊只能碰撞兩次，那麼 k 的值必須滿足什麼條件？

2. Part I 第 I 部分

A ball with mass m moving towards North at speed v_1 hits a moving wall that it makes a 45° angle with the East and is travelling towards West at speed v_0 . The ball then bounces away from the wall at speed v_2 at South θ of West as shown in the Fig. 2a. The wall is very heavy, so its velocity does not change due to the collision.

質量為 m 的球以速度 v_1 向北移動，撞到與東方成 45° 角的移動牆，並以速度 v_0 向西移動。然後球以速度 v_2 在西面的南 θ 處彈離牆壁，如圖 2a 所示。牆很重，所以它的速度不會因碰撞而改變。

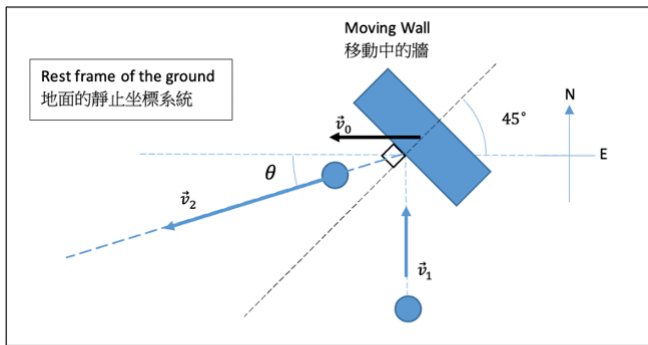

Fig. 2a

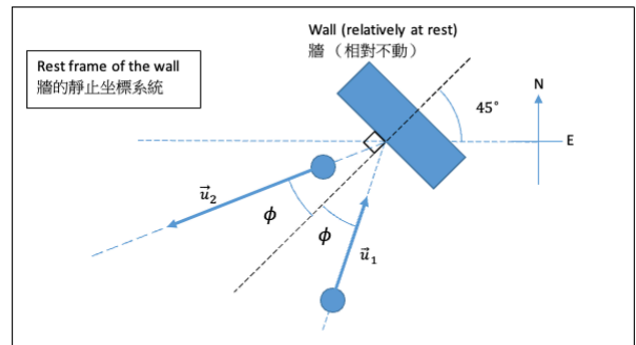

Fig. 2b

(a) [5] Assume that the collision is elastic in the rest frame of the wall. Find the speeds u_1 and u_2 , and the angle ϕ in the rest frame of the wall shown in Fig. 2b, in terms of v_0, v_1 and m .

(a) [5] 假設碰撞在牆的靜止坐標系統中是彈性的。求速度 u_1 和 u_2 ，以及牆的靜止坐標系統中的角度 ϕ ，如圖 2b 所示。答案以 v_0 、 v_1 和 m 表示。

(b) [4] Find angle θ and speed v_2 in the rest frame of the ground (Fig. 2a) in terms of v_0, v_1 and m .

(b) [4] 求在地面的靜止坐標系統 (圖 2a) 中的角度 θ 和速度 v_2 。答案以 v_0 、 v_1 和 m 表示。

Part II 第 I I 部分

Gravity Assist is a technique to achieve acceleration (or deceleration) of a spacecraft using the gravity of the planet that the spacecraft is flying by. The drawing below shows an example of how a spacecraft launched from Earth executes a gravity assist when flying by Jupiter to change direction and accelerate to fly far away from the Sun's gravity.

「重力輔助」是一種利用航天器飛過的行星的重力來實現航天器加速（或減速）的技術。下圖展示了從地球發射的航天器在飛越木星時如何執行重力輔助從而改變方向並加速飛離太陽引力的例子。

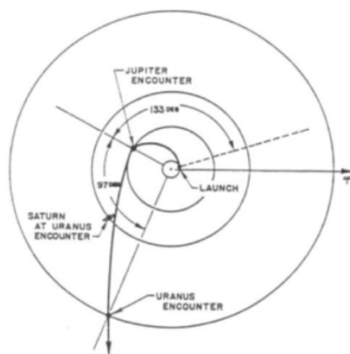

Fig. 2c

Reference: Flandro, G. (1966), "Fast reconnaissance missions to the outer solar system utilizing energy derived from the gravitational field of Jupiter," *Astronautica Acta*, 12: 329-337.

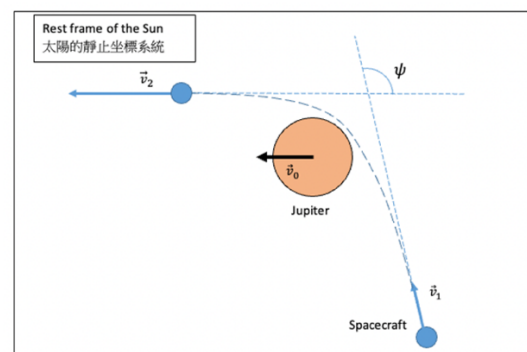

Fig. 2d

Consider a spacecraft executing gravity assist flying by Jupiter as shown in Fig. 2d. In the rest frame of the Sun (assuming the Sun is absolutely at rest), the Jupiter is moving to the left at speed v_0 . The spacecraft comes in at incident speed v_1 and exits at speed v_2 (v_2 will not change any further) with a deflection of its trajectory with angle ψ and \vec{v}_2 is parallel to \vec{v}_0 .

考慮一個由木星執行重力輔助飛行的航天器，如圖 2d 所示。在太陽的靜止坐標系中（假設太陽完全靜止），木星以速度 v_0 向左移動。航天器以入射速度 v_1 進入木星引力範圍並以速度 v_2 離開（ v_2 不會再改變），其軌跡偏轉角度 ψ 並且 \vec{v}_2 平行於 \vec{v}_0 。

The mass of Jupiter is much larger than the spacecraft. One can assume that, in the rest frame of Jupiter, the spacecraft's mechanical energy (sum of its kinetic energy and gravitational potential energy due to Jupiter) is conserved when it flies by. 木星的質量比航天器大得多。可以假設，在木星的靜止坐標系統中，航天器飛過木星時的機械能（其動能和木星引力勢能之和）守恒。

(c) [4] Find the speed v_2 of the spacecraft when it flies away from Jupiter in the rest frame of the Sun in terms of v_0, v_1 and ψ .

(c) [4] 求航天器在太陽靜坐標系統中飛離木星的速度 v_2 。答案以 v_0 、 v_1 和 ψ 表示。

(d) [2] Given $\psi = 120^\circ$, find the speed of spacecraft v_1 in terms of v_0 such that the spacecraft exits at three times its incident speed $v_2 = 3v_1$.

(d) [2] 設 $\psi = 120^\circ$ ，要使得航天器以其入射速度的三倍的速度離開 $v_2 = 3v_1$ ，求航天器 v_1 的速度。答案以 v_0 表示。

3. [15 points] We consider an asteroid coming across the Earth, tracing out a hyperbolic trajectory on the x-y plane as

$$r = \frac{\ell}{1 + e \cos \theta}$$

where $r = \sqrt{x^2 + y^2}$ is the radial distance of the current asteroid position measured from the Earth at origin and θ is the angle measured from the positive x-axis, as shown in the figure below. The parameters of the trajectory, ℓ and e , are positive constants, which can be determined from the initial condition. For an asteroid coming at a perpendicular distance b and speed v_{inf} at infinity, the asteroid has a speed v_p , pointing in the negative y-direction, at the closest point P of radial distance r_p on the x-axis. The asteroid will then leave to infinity with its original direction being deflected by an angle ϕ if the asteroid has not hit the Earth.

3. [15 分] 我們考慮一顆行星從地球經過，其在 x-y 平面上追蹤出一條雙曲線軌跡，其方程式為

$$r = \frac{\ell}{1 + e \cos \theta}$$

其中 $r = \sqrt{x^2 + y^2}$ 是行星當前位置與地球原點之間的距離，而 θ 則是從正 x 軸起算的角度，如下圖所示。軌跡的參數 ℓ 和 e 是正常數，可以從初始條件中確定。對於一顆從無限遠處以速度 v_{inf} 以及與地球的垂直距離為 b 運動的行星，行星在最靠近點 P 時有一速度 v_p ，其指向負 y 方向。如果行星未撞擊地球，則它將以偏轉角度 ϕ 離開地球，並保持其原來的方向。

In this problem, we have assumed the Earth is in an inertial reference frame as simplification. For the hyperbolic trajectory, we have $e > 1$ and θ satisfies $1 + e \cos \theta > 0$. Unlike circular motion, the velocity vector $\mathbf{v} = v_x \hat{x} + v_y \hat{y}$ is not always perpendicular to the position vector $\mathbf{r} = r \hat{r} = x \hat{x} + y \hat{y}$. To ease the discussion, it is given that $\mathbf{v} \perp (\hat{r} + e \hat{x})$, as a geometric fact of the hyperbola. We are also given constants: Mass of Earth $M = 5.97 \times 10^{24}$ kg. Radius of Earth $R = 6.38 \times 10^6$ m.

在這個問題中，我們假設地球處於慣性參考系中作為簡化。對於雙曲線軌跡，我們有 $e > 1$ 並且 θ 滿足 $1 + e \cos \theta > 0$ 。不像圓形運動，速度向量 $\mathbf{v} = v_x \hat{x} + v_y \hat{y}$ 並不總是垂直於位置向量 $\mathbf{r} = r \hat{r} = x \hat{x} + y \hat{y}$ 。為了方便討論，已知 $\mathbf{v} \perp (\hat{r} + e \hat{x})$ ，這是雙曲線的一個幾何事實。我們還給出常數：地球的質量 $M = 5.97 \times 10^{24}$ kg。地球的半徑 $R = 6.38 \times 10^6$ m。

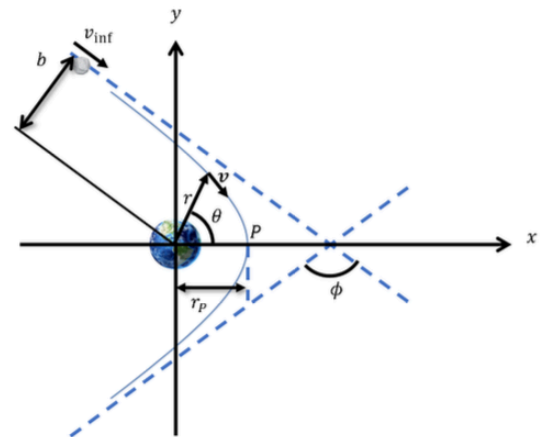

(a) [3] Suppose the asteroid is able to hit the Earth. Find the minimum speed at the moment of impact. Please ignore the effect of atmosphere in decelerating the asteroid.

(a) [3] 假設小行星能夠撞擊地球。找出撞擊時的最小速度。請忽略大氣層在減速小行星方面的影響。

(b) [2] Now, we are given the initial conditions that $b = 10,000$ km and $v_{\text{inf}} = 20$ km s^{-1} while other parameters such as ℓ , e and r_p are assumed to be derived quantities. According to Kepler's second law which is valid even if the trajectory is hyperbolic, the trajectory sweeps out equal areas in equal intervals of time. Calculate the numerical value of the sweeping area per unit time which should be a constant along the whole trajectory.

(b) [2] 現在，我們假設初值條件為 $b = 10,000$ km 和 $v_{\text{inf}} = 20$ km s^{-1} ，而其他參數如 ℓ , e 和 r_p 被假定為可推導得出的物理量。根據開普勒第二定律，即使軌跡是雙曲線的，軌跡在相等時間間隔內掃過相等的面積。計算每單位時間的橫掃面積的數值，這個數值應該在整條軌跡上保持不變。

(c) [5] With the given initial condition, calculate the numerical value of the closest radial distance r_p . You may need to use the results of last part.

(c) [5] 根據給定的初始條件，計算最接近地球的徑向距離 r_p 的數值。你可能需要使用上一部分的結果。

(d) [5] With the same initial condition, calculate the angle of deflection ϕ . (Hint: You can consider a point of the trajectory on the y-axis)

(d) [5] 在相同的初始條件下，計算偏轉角度 ϕ 。(提示：你可以考慮軌跡在 y 軸上的一個點)

4. [15 points] In an air show two helicopters are at rest at the same height above ground at a distance D to each other. At $t = 0$, one of them launches a projectile, called A , with speed v_A at an angle of θ_A measured upward from the direction of the other helicopter. At the same time, the other helicopter also launches a projectile, called B , with speed v_B at an angle of θ_B measured upward from the same direction, as shown in the figure below. It is given that the changes in heights during the motions of the projectiles are much smaller than the radius of the Earth and the helicopters are very high above ground so that there is no need to consider the projectiles hitting the ground. Ignore air resistance.

4. [15 分] 在一次飛行表演中，兩架直升飛機停留在彼此距離為 D 且距離地面相同高度的位置。在 $t = 0$ 時，如下圖所示，其中一架直升飛機發射一枚稱為 A 的彈丸，速率為 v_A ，從另一架直升機的方向向上測量的發射角度為 θ_A 。與此同時，另一架直升機也發射了一枚彈丸，稱為 B ，速率為 v_B ，從同一方向向上測量的發射角度為 θ_B 。假設彈丸運動過程中的高度變化遠小於地球半徑，且直升機離地很高，因此無需考慮彈丸撞擊地面的情況。可忽略空氣阻力。

(a) [5] Find the minimum distance and the time when A and B are at this distance. Express your answers in terms of D , v_A , v_B , θ_A and θ_B . Find all possible answers in different cases.

(a) [5] 求 A 、 B 間的最小距離及 A 、 B 達到這個距離的時間。用 D , v_A , v_B , θ_A 和 θ_B 表達你的答案。考慮所有可能情況下的不同答案。

(b) [5] Hence, or otherwise, find the condition in terms of v_A , v_B , θ_A and θ_B , such that B will hit A , and the time taken for B to hit A after being launched, in terms of D , v_A , v_B , θ_A and θ_B .

(b) [5] 據上，或以其他方法，找到以 v_A , v_B , θ_A 和 θ_B 表示的 B 將擊中 A 的條件，以及以 D , v_A , v_B , θ_A 和 θ_B 表示的 B 在發射後擊中 A 的時間。

(c) [5] Hence, or otherwise, find θ_B in terms of θ_A such that B will hit A if $v_A = v_B$ and $0 \leq \theta_A < \frac{\pi}{2}$. At what time, in terms of D , v_A , and θ_A , will B hit A ?

(c) [5] 設 $v_A = v_B$ 及 $0 \leq \theta_A < \frac{\pi}{2}$ ，據上，或以其他方法，找到以 θ_A 表示的 θ_B ，使得 B 會擊中 A 。找到以 D , v_A , 和 θ_A 表示的 B 擊中 A 的時間。

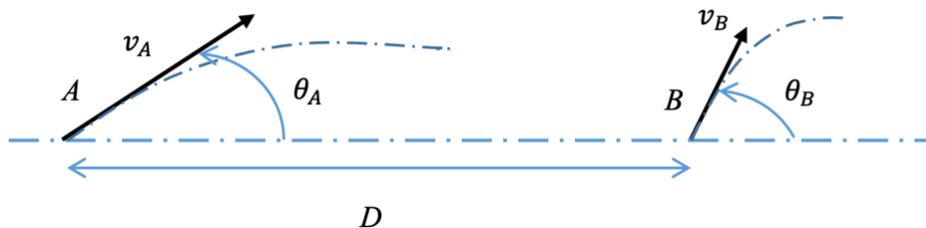

~ END OF PAPER 全卷完 ~